

Natural & Painted With Flange (1590 Series)

Bottom flange is an aluminum plate, welded onto the base of the enclosure...

Lid screws are exposed for easy enclosure access...

Countersunk lid with machine screws into drilled and tapped holes...

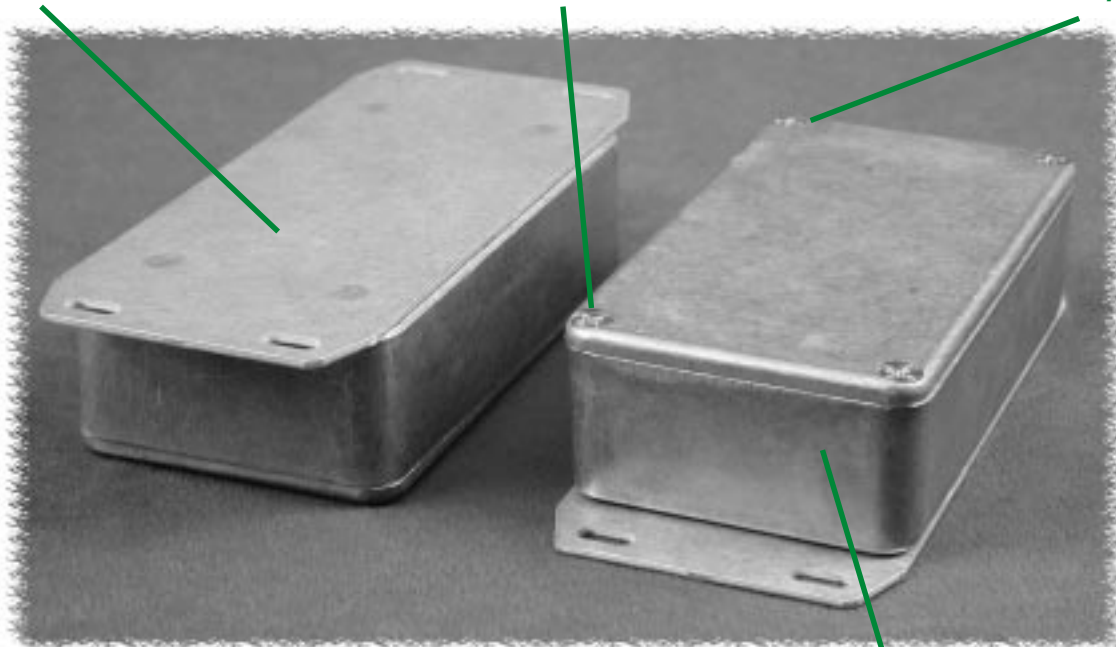

Vibra finished for a smooth surface with no sharp edges...

OTHER KEY FEATURES

- Rugged, diecast aluminum alloy (tough yet easy to machine), electronic instrument enclosure.
- Lap joint construction provides protection against access of dust and splashing water. Also provides for improved EMI/RFI shielding.
- Painted version (shown below) is painted with tough polyester powder paint for a lasting finish, even after machining.
- Four (or 6 in 1590D, 1590DD & 1590E, 8 in 1590F) 6-32 x 1/2" machine screws secure lid - into tapped holes.
- Designed to meet IP54
- Replacement screws for natural finish series, nickel plated, 6-32 x 1/2" - **1590MS100** - Package of 100
- Replacement black chromate screws for black series, 6-32 x 1/2" - **1590MS50BK** - Package of 50

Lap joint construction - lip masked to ensure good EMI/RFI connection to base...

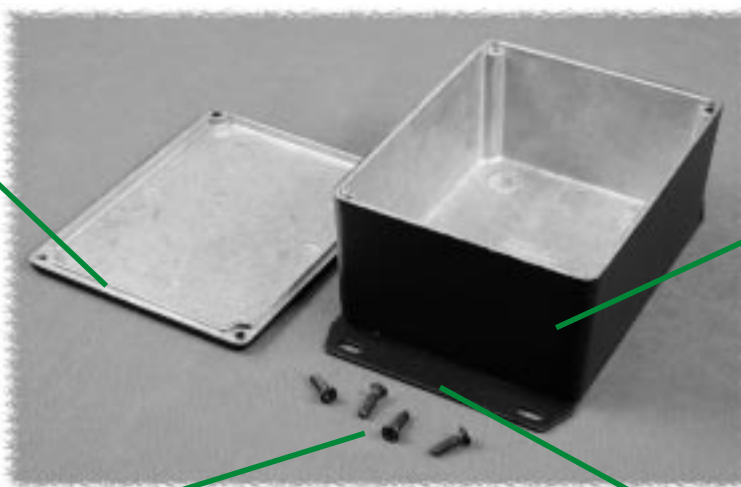

Vibra finished for a smooth surface with no sharp edges, then painted with tough polyester powder paint...

Enclosure uses machine screws into drilled & tapped holes matched to enclosure color...

Bottom flange is an aluminum plate, welded onto the base of the enclosure...

Natural & Painted With Flange (1590 Series)

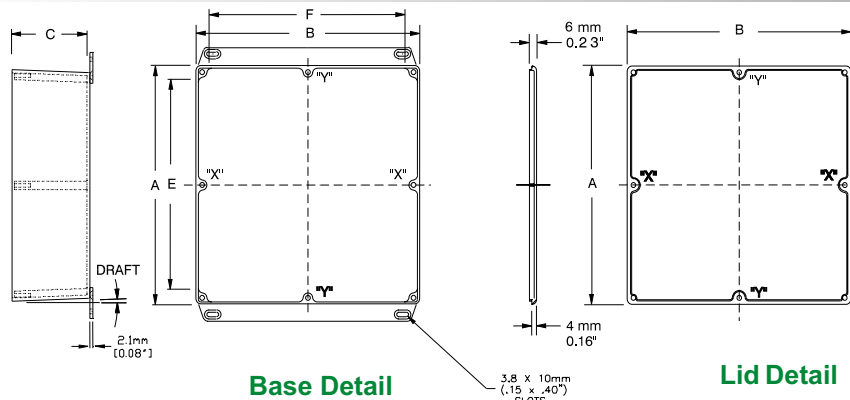

Base Detail

Lid Detail

Part Number		Units	Dimensions					Apx. Draft
Unpainted	Black		A	B	C (No Lid)	E	F	
1590LLBF	1590LLFBK	inch mm	1.97 50	1.97 50	0.83 21	1.22 31	1.22 31	1°15'
1590LBF	1590LBFBK	inch mm	1.99 50.5	1.99 50.5	1.06 27	1.36 34.5	1.36 34.5	1°15'
1590HF	1590HFBK	inch mm	2.07 52.5	1.50 38	1.06 27	1.41 35.9	.86 21.8	1°15'
1590YF	1590YFBK	inch mm	3.62 92	3.62 92	1.50 38	2.70 69	2.70 69	1°15'
1590AF	1590AFBK	inch mm	3.64 92.5	1.52 38.5	1.06 27	3.01 76.5	.89 22.5	1°15'
1590GF	1590GFBK	inch mm	3.94 100	1.97 50	0.83 21	3.31 84	1.34 34	1°15'
1590SF	1590SFBK	inch mm	4.35 110.5	3.21 81.5	1.57 40	3.72 94.5	2.58 65.5	1°15'
1590BF	1590BFBK	inch mm	4.39 111.5	2.34 59.5	1.06 27	3.76 95.5	1.71 43.5	1°15'
1590BBF	1590BBFBK	inch mm	4.67 118.5	3.68 93.5	1.18 30	4.04 102.5	3.05 77.5	1°15'
1590UF	1590UFBK	inch mm	4.70 119.5	4.70 119.5	2.17 55	4.07 103.5	4.07 103.5	1°15'
1590VF	1590VFBK	inch mm	4.70 119.5	4.70 119.5	3.54 90	4.07 103.5	4.07 103.5	1°15'
1590CF	1590CFBK	inch mm	4.72 120	3.70 94	2.07 52.5	4.09 104	3.07 78	2°
1590QF	1590QFBK	inch mm	4.72 120	4.72 120	1.18 30	4.09 104	4.09 104	1°15'
1590TF	1590TFBK	inch mm	4.74 120.5	3.13 79.5	2.17 55	4.11 104.5	2.50 63.5	1°15'
1590N1F	1590N1FBK	inch mm	4.77 121.1	2.60 66	1.39 35.3	4.09 103.8	1.92 48.7	1°15'
1590KKF	1590KKFBK	inch mm	4.92 125	4.92 125	2.10 53	4.13 105	4.13 105	1°15'
1590KF	1590KFBK	inch mm	4.92 125	4.92 125	2.95 75	4.27 108.5	4.27 108.5	1°15'
1590JF	1590JFBK	inch mm	5.71 145	3.74 95	1.77 45	5.06 128.5	3.09 78.5	2°
1590P1F	1590P1FBK	inch mm	6.01 153	3.24 82	1.81 46	5.38 137	2.48 63	2°
1590DDF	1590DDFBK	inch mm	7.38 187.5	4.70 119.5	1.30 33	6.77 172	4.07 103.5	1°15'
1590DF	1590DFBK	inch mm	7.38 187.5	4.70 119.5	2.05 52	6.75 171.5	4.07 103.5	2°
1590EF	1590EFBK	inch mm	7.38 187.5	4.70 119.5	3.07 78	6.75 171.5	4.07 103.5	2°
1590FF	1590FFBK	inch mm	7.38 187.5	7.38 187.5	2.48 63	6.75 171.5	6.75 171.5	2°
1590R1F	1590R1FBK	inch mm	7.55 192	4.38 111	2.24 57	6.92 176	3.76 95.4	2°

Notes: Assembled height = dimension "C" + .16" (4.0 mm). Wall & lid thickness is roughly .08" (2 mm) and varies with draft due to part being cast. Posts "X" exist on parts 1590D, 1590DD & 1590E. Posts "X" & "Y" exist on part 1590F. For detailed drawings, CAD files or color photos visit our website at: www.hammondmgf.com

Diecast



CANADA
Guelph, Ontario (519) 822-2960
St. Laurent, Quebec (514) 343-9010
USA
Cheektowaga, NY (716) 651-0086

www.hammondmgf.com

EUROPE
Basingstoke, UK +44 1256 812812

AUSTRALASIA
Queenstown, SA, Australia +61 8 8240 2244